

Rev 2.0
2025

NEO

Installation Manual

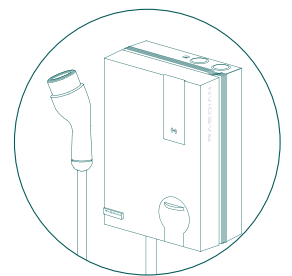
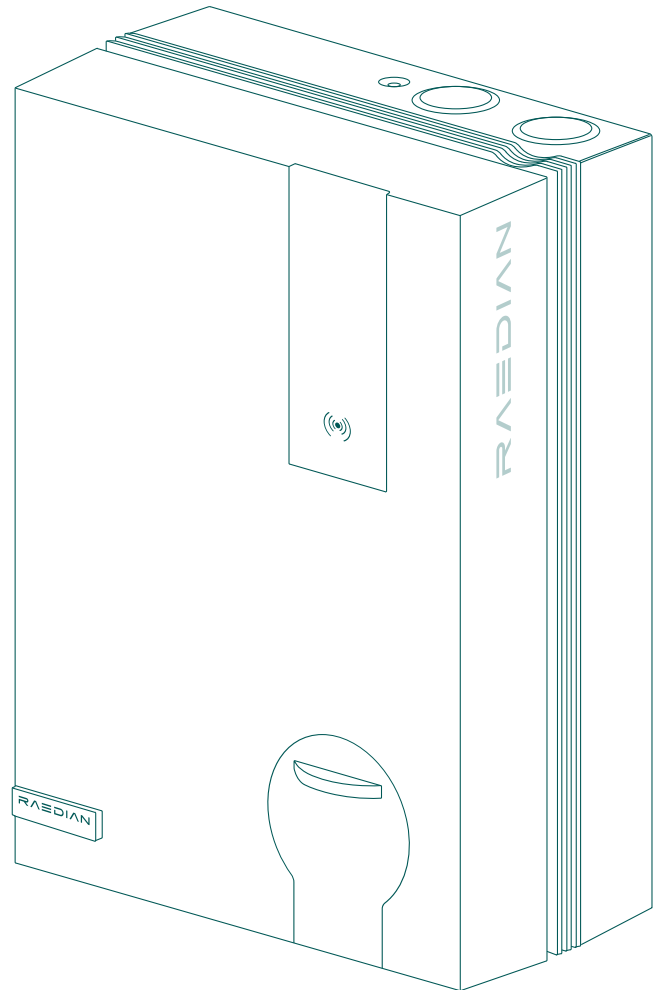

NEO NEO PLUS

PREMIUM SMART CHARGING



www.raedian.com

RAEDIAN

Table of contents

1.	Disclaimer and safety warning	2	7.	Technical specifications	15
1.1	Disclaimer	2	7.1	General	15
1.2	Improper use	2	7.2	Connectivity	15
1.3	Copyright	2	7.3	Operating conditions	15
1.4	Trademarks	2	7.4	Compliance	15
1.5	Languages	2	7.5	Mechanical	15
1.6	Purpose and intended audience	2			
1.7	Explanation of text instructions used	2			
1.8	Safety symbols	3			
1.9	General safety	3			
2.	product overview	4			
2.1	Exterior view-socket variant	4			
2.2	Exterior view-cable variant	5			
2.2	Internal view	6			
3.	Installation and connection	7			
3.1	Safety announcements	7			
3.2	Assembly and installation requirements	7			
3.3	Scope of delivery	8			
3.4	Tools suggestion	8			
3.5	Installation and connection	9			
4.	Acceptance test	13			
4.1	Pre-Testing checks	13			
4.2	Power on	13			
4.3	Perform charging test in plug and play mode	13			
5.	HMI description	13			
5.1	Status indication	13			
5.2	OLED Display	13			
6.	Configuration	14			
6.1	Install RAEDIAN INSTALL APP	14			
6.2	Connect with the charger	14			
6.3	Configuration	14			

1.Disclaimer and safety warning

1.1 Disclaimer

The information in this document is for informational purposes only, is provided "as is," and may be subject to change without notice. Although RAEDIAN has made its best efforts to keep this document as accurate and up-to-date as possible, RAEDIAN, including its subsidiaries, does not assume any liability for its correctness or completeness. RAEDIAN shall not be liable for any defects or damages resulting from the use of the information contained herein.



NOTE

This document is subject to updates and changes. Errors and omissions are exceptional.

Any deviation from RAEDIAN's assembled products, including but not limited to specific modifications to the product, such as the placement of stickers or the application of different colors (collectively referred to as "Customization"), may affect the product's functionality, user experience, appearance, quality, and/or lifespan (hereinafter referred to as the "Customized Product"). RAEDIAN shall not be liable for any damage to, or caused by, the Customized Product if such damage results from the applied Customization.

RAEDIAN waives all liability and claims for compensation, including but not limited to any type of damage, product and accessories warranty, in the following cases:

- Failure to comply with the general instructions or specific operating conditions in this manual.
- Improper use of the product.
- External damage.
- Failures caused by the power grid or the 4G service provider.
- Installation, commissioning, activation, or faulty repair or maintenance performed by an unqualified person.
- Modification or configuration of the product or accessories without RAEDIAN's knowledge.
- Use of the charging station outside the operational conditions specified in this manual.
- Use of spare parts not approved or manufactured by RAEDIAN.
- Events beyond RAEDIAN's control (force majeure).
- Malfunction of an open charge point back-office system.
- Damage to the electric vehicle.

1.2 Improper use

The charging station is safe when used as intended. Any other use or modifications to the charging station are considered improper use and, therefore, are not permitted.

Operators, owners, or qualified technicians are responsible for any personal injury or property damage caused by improper use.

1.3 Copyright

The reproduction, distribution, and use of this document, as well as the communication of its contents to any third parties, are strictly prohibited without explicit authorization from

RAEDIAN or any of its affiliates. Any permitted use must always be in accordance with good practices and ensure that no harm is caused to RAEDIAN or through misleading the consumer.

1.4 Trademarks

RAEDIAN® is trademark registered by RAEDIAN. Any unauthorized use of this trademark is, therefore, illegal.

1.5 Languages

The English version of this document is the original source. Documents in other languages are translations of this source. In case of any ambiguity or discrepancy between the different language versions, the English version shall prevail.

1.6 Purpose and intended audience

This manual applies to the NEO/NEO Plus model produced by RAEDIAN. NEO/NEO PLUS is intended exclusively for charging electric vehicles and, when installed correctly, may be used by untrained individuals. Follow this manual to correctly install and commission the charging station.

Installation, commissioning, and maintenance of this charging station must only be carried out by a qualified electrician. It is essential that the qualified technician has:

- Expertise in all relevant general and specific safety rules and incident prevention measures.
- Comprehensive knowledge of applicable electrical regulations.
- Ability to identify risks and avoid potential hazards.
- Acknowledgment of having received and read these installation and operation instructions.

1.7 Explanation of text instructions used

The safety warnings and precautions in this document are as follows:



DANGER

Signal word used to indicate an imminent or serious injury.



WARNING

Signal word used to indicate a potentially hazardous situation which, if not avoided, could cause death or serious injury.



CAUTION

Signal word used to indicate a potentially hazardous situation which, if not avoided, could cause minor or moderate injury.

1. Disclaimer and safety warning

NOTE



Signal word used to provide additional information or information on possible product damage.

1.8 Safety symbols

The following warning pictograms are attached to (parts of) the charging station:



Dangerous voltage



Protective earth

1.9 General safety

When installing or using the charging station, please follow below safety regulations:



DANGER

Do not install or use the charging station near explosive or highly flammable materials.



DANGER

Do not use the charging station if it is partially submerged in water.



DANGER

Do not install or use the charging station if it is damaged, or if the plugs and cables are defective. Contact the charge point operator to repair any defects immediately.



DANGER

Keep children and individuals who are unable to assess the risks associated with using this product away.

More extensive safety information can be found in the relevant sections of this document.

2. Product overview

2.1 Exterior view-socket variant

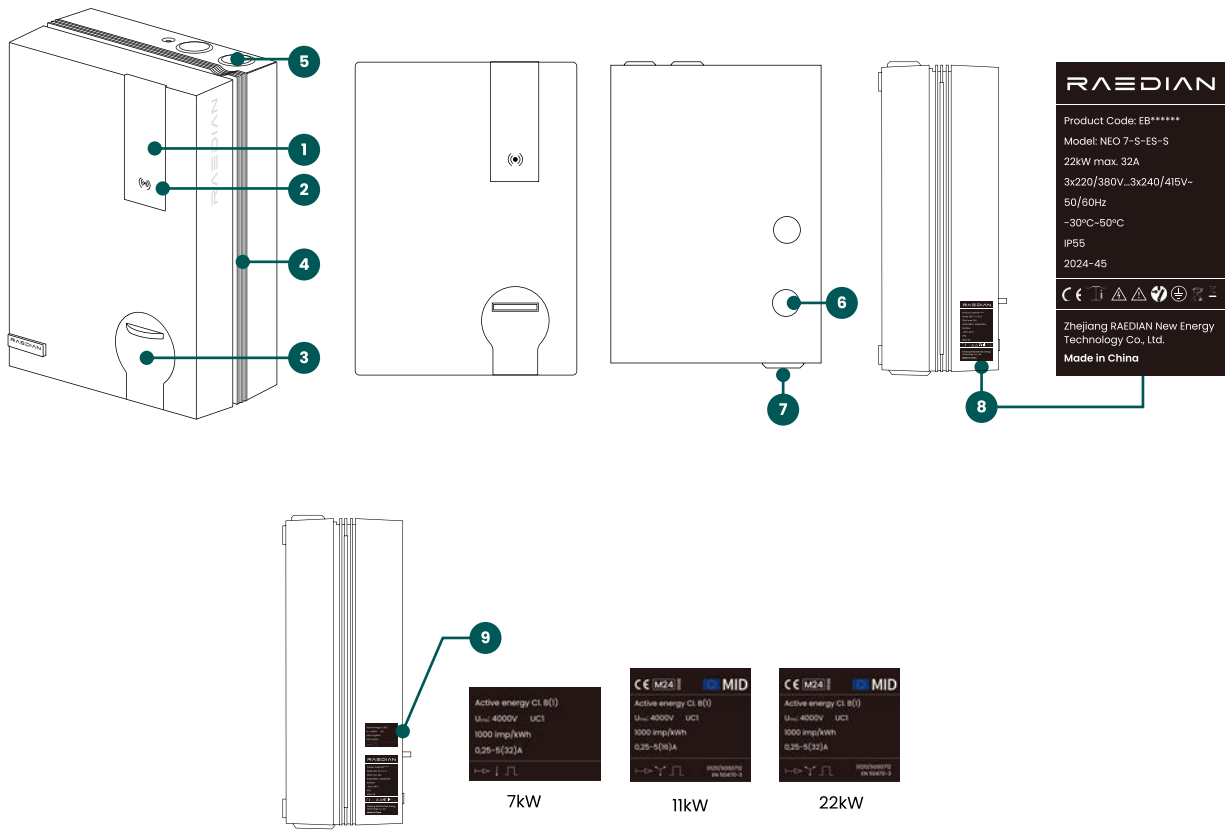

No.	Item	NEO	NEO Plus
1	Display	✓	✓
2	RFID card reader	✓	✓
3	Type 2 socket	✓	✓
4	LED stripe	✓	✓
5	Top cable entry	✓	✓
6	Rear cable entry	✓	✓
7	Bottom cable entry	✓	✓
8	Nameplate	✓	✓
9	Meter label	-	✓

2. Product overview

2.2 Exterior view-cable variant

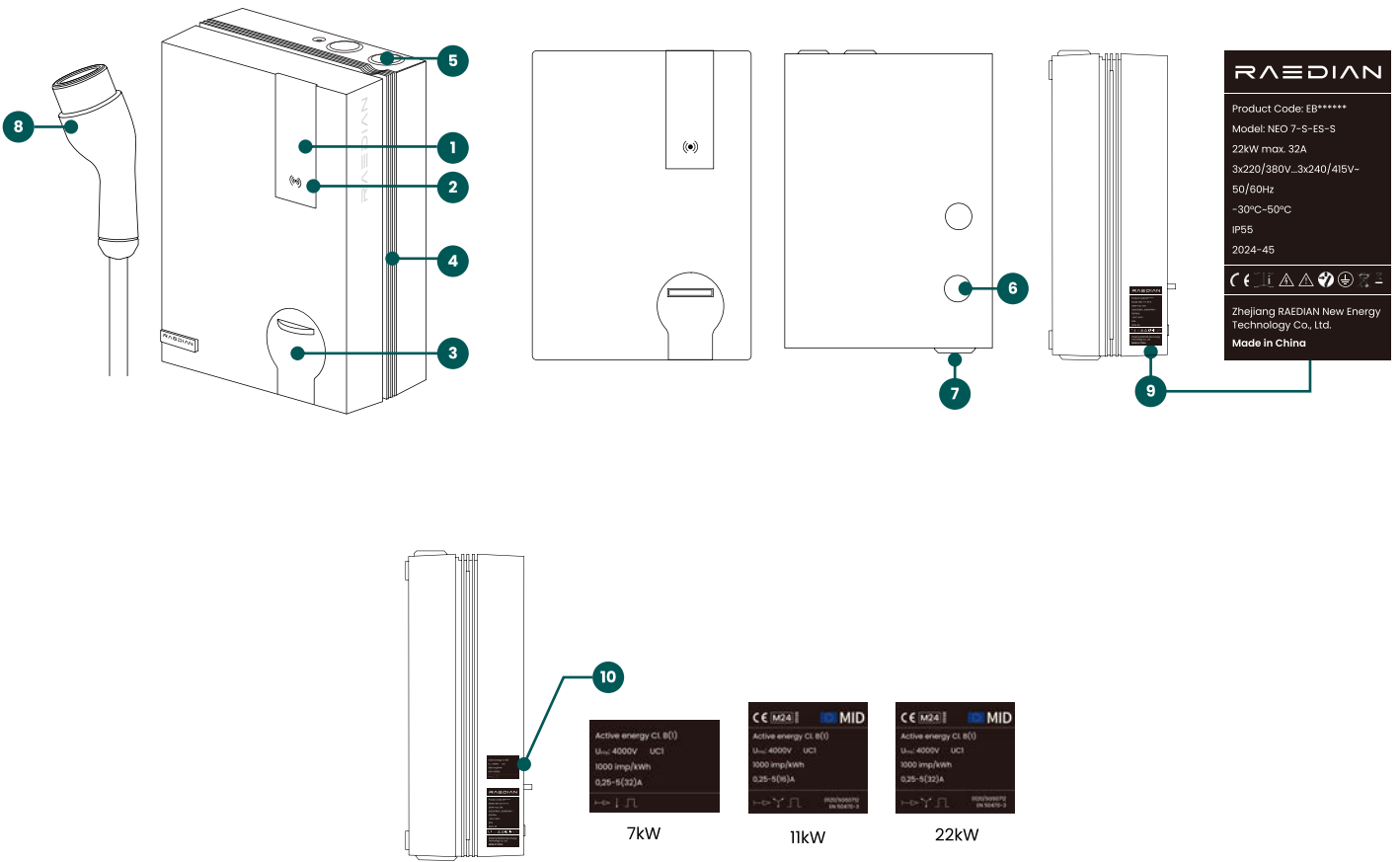

No.	Item	NEO	NEO Plus
1	Display	✓	✓
2	RFID card reader	✓	✓
3	Type 2 connector holder	✓	✓
4	LED stripe	✓	✓
5	Top cable entry	✓	✓
6	Rear cable entry	✓	✓
7	Bottom cable entry	✓	✓
8	Charging cable	✓	✓
9	Nameplate	✓	✓
10	Meter label	-	✓

2. Product overview

2.3 Internal view

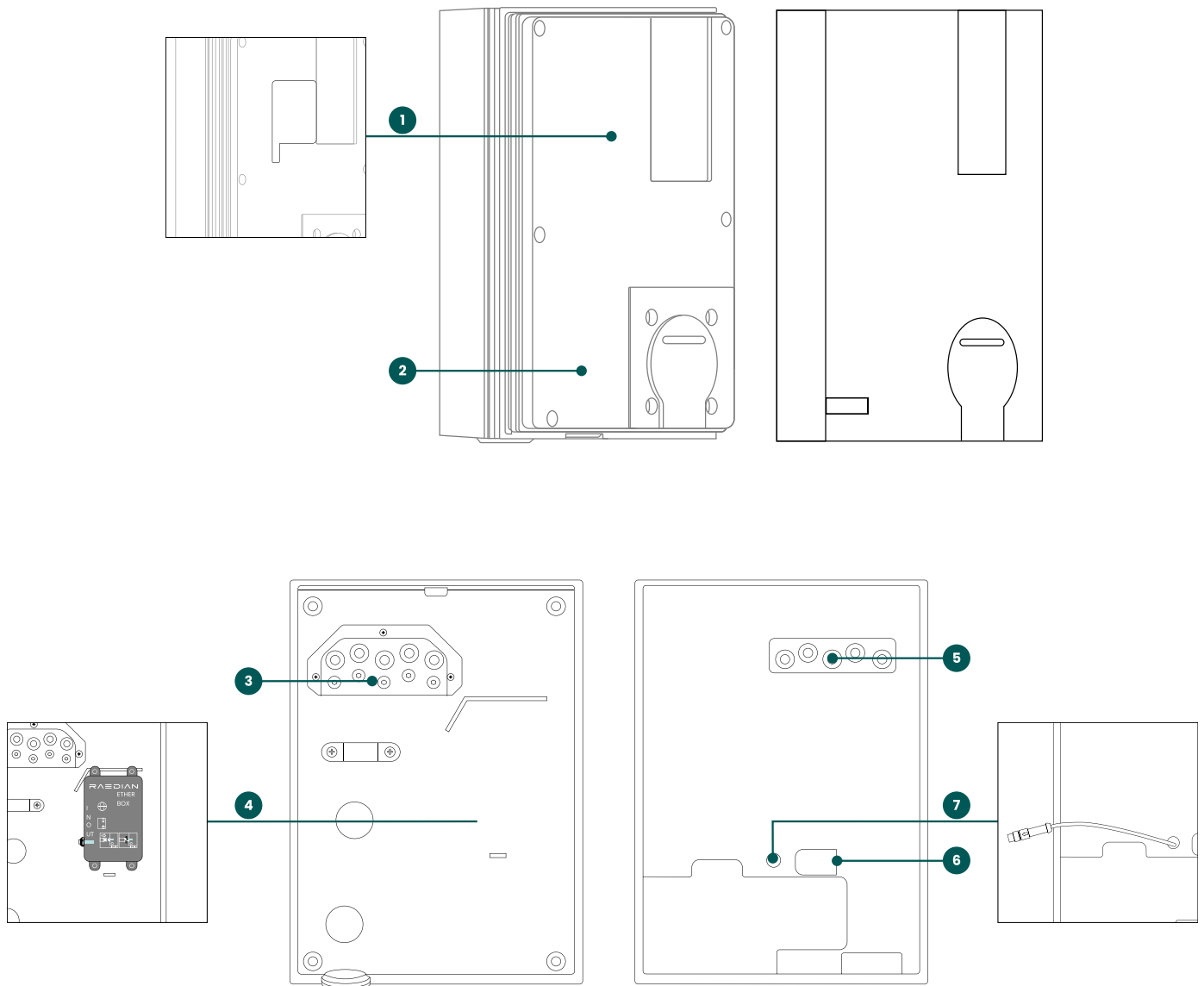

No.	Item	NEO	NEO (4G)	NEO (4G+LAN)
1	SIM card insert area	-	✓	✓
2	Charge core	✓	✓	✓
3	Terminal block cover plate	✓	✓	✓
4	Etherbox	-	-	✓
5	Terminal block for the power supply	✓	✓	✓
6	RJ45 jet for CT clamps and RS-485	-	-	✓
7	Cable assembly for Etherbox	✓	✓	✓

3. Installation and connection

3.1 Safety announcements

⚠ DANGER
The installation, decommissioning, and maintenance of the charging station must be performed only by a qualified electrician.

⚠ DANGER
Risk of Fatal Injury: Improper installation of the charging station may result in serious or fatal injuries. Failure to comply with electrical safety regulations can lead to life-threatening situations.

⚠ DANGER
The electrical system must be completely disconnected from all power sources before performing any installation or maintenance work.

⚠ DANGER
Electrical components inside the charging station may still retain a charge even after disconnection. Always use appropriate testing equipment to ensure no residual current is present before starting work.

⚠ WARNING
Do not perform installation work during flooding, rain, or when air humidity exceeds 95%.

⚠ WARNING
Charging connector adapters or conversion adapters are not allowed to be used.

⚠ CAUTION
Extreme environmental conditions can affect the charger's performance. Select a suitable installation location to protect it from extreme temperatures, moisture, and other harsh elements. If necessary, consider additional protective measures.

⚠ CAUTION
The installer is responsible for selecting the correct cable diameter and ensuring compliance with relevant standards and legislation.

3.2 Assembly and installation requirements

3.2.1 Placement requirement

When selecting a location to install the charging station, the following criteria must be taken into account:

- Always comply fully with local safety laws and regulations.
- The vehicle's charging port must be easily accessible with the charging cable.
- Install the charging station in a location where the charging cable (approximately 5 to 7.5 meters) can be used without putting tension on the cable.
- Cable routing must follow local professional standards and regulations.
- The following instructions cover only wall-mounted installation. The charger can also be mounted on a pedestal, which is available as an optional accessory. Installation instructions for the pedestal are included in the package.

- Install the charger upright on a solid wall with a minimum load-bearing capacity of 100 kg. Other installation methods may damage the charger.
- Recommended installation height: 800-1200 mm.

3.2.2 RCD requirement

- An integrated Residual Current Device, compliant with IEC 62955, continuously monitors for DC residual currents. If a residual current exceeding 6 mA DC is detected, the charging session will automatically be stopped.
- The integrated RCD automatically conducts a self-test between charging sessions.
- The integrated RCD operates independently and does not interfere with external protective devices.

An external RCBO is required as below:

Input	Specification	Remark
1-phase	2P, 40A RCBO, at least Type A, Characteristic B/C	50 Amp is recommended if the ambient temperature is higher than 40°C
3-phase	4P, 40A RCBO, at least Type A, Characteristic B/C	

3.2.3 Grounding

EV chargers must be grounded per local electrical standards, with specific methods for TN, TT, and IT systems, ensuring safety and compliance.

TN system: separate PE cable

TT system: separately installed grounding electrode < 100 Ohm spreading resistance

IT system: connected to a shared reference (common earth) with other metal parts

3.2.4 Power supply cable

Minimum recommended cable cross-section (based on an assumed maximum cable length of 50 meters):

3-phase 11 kW charging, 16 A selected per phase: 5 x 4 mm²

1-phase 7.4 kW charging, 32 A per phase: 3 x 6 mm²

3-phase 22 kW charging, 32 A per phase: 5 x 6 mm²

3.2.5 SC Kit

The SC Kit is an optional accessory that enables the dynamic load balancing and solar charging. Installation instructions are included its package.

3. Installation and connection

3.3 Scope of delivery

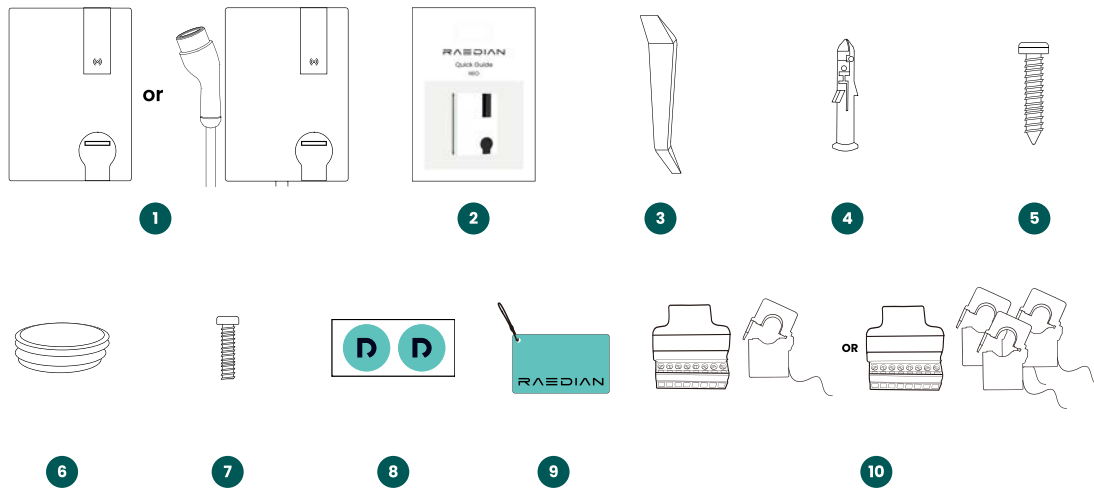

No.	Item	Quantity
1	NEO/NEO Plus	1
2	Quick guide	1
3	Removal Kit	1
4	Plastic anchor	4
5	Wall-mounting screw	4

No.	Item	Quantity
6	Rubber plug	2
7	Security screw	2
8	Security label	1
9	RFID card	2
10	CT Kit (Single phase)	1
	CT Kit (Three phase)	1

3.4 Tools Suggestion

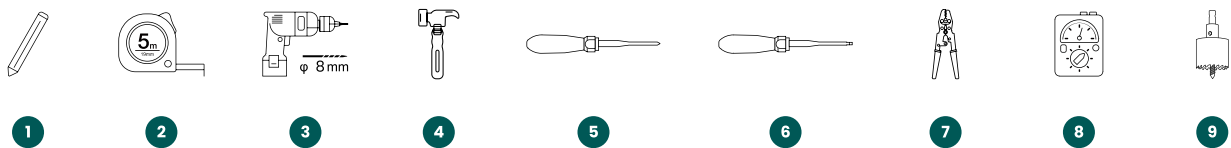

No.	Item
1	Pencil or marker
2	Measuring tape
3	Drilling machine
4	Hammer
5	Phillips screwdriver

No.	Item
6	Slotted screwdriver
7	Ethernet cable pliers
8	Voltmeter or digital multimeter
9	M25 hole saw (for plastic)

3. Installation and connection

3.5 Installation and connection

3.5.1 SIM card Installation



NOTE

Applicable to RAEDIAN NEO/NEO Plus models that support 4G with a user SIM card (models with-ES).

Two SIM options:

User SIM: Nano SIM, Settable APN user name and password.

eSIM: Integrated, activated by Lifetime Connectivity Key (please contact reseller or distributor).

Installation procedure:

1. Separate the front cover and charge core of the charger. Remove the card slot cover on the charge core.

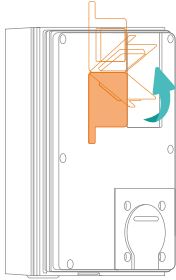

2. Insert User SIM card.

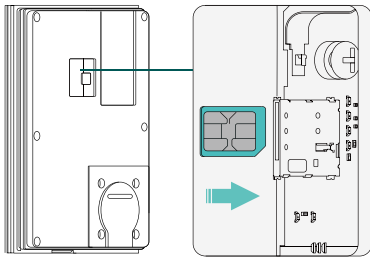

3. Peel off the film on the card slot cover and attach the cover to the charge core.

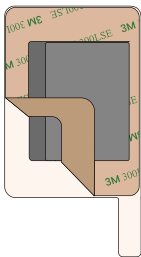

4. Securely install the front cover onto the charge core.

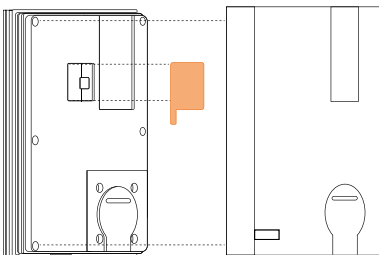

NOTE

Whether the SIM card is inserted or not, the film need to be removed and the cover need to be attached to the charge core.

3.5.2 Mount the wall bracket

- Place the backplate on a clear and solid wall with a bearing capacity of at least 100 kg. Recommended height: 800-1000 mm.
- Ensure it is level, and use a pencil to mark the positions for 4 drilling holes.
- Drill 4 holes at the marked locations. Recommended depth and diameter: 50 mm; $\phi 8$ mm.
- Insert 4 plastic anchors into the drilled holes.
- Mount the backplate and fasten it using four wall-mounting screws.

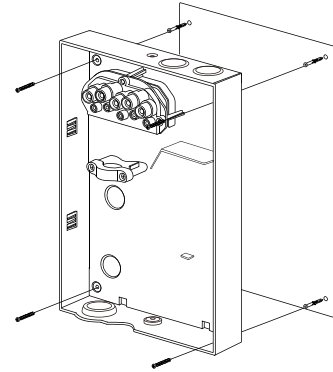

3.5.3 Electrical installation

Make sure you know if the charging station needs to be installed as a single-phase or three-phase variant.

1. There are three entries available for input wiring: bottom (recommended), top and rear wiring entry. For the top and rear entry, use an M25 hole saw to create the hole and install the rubber plug over the hole.

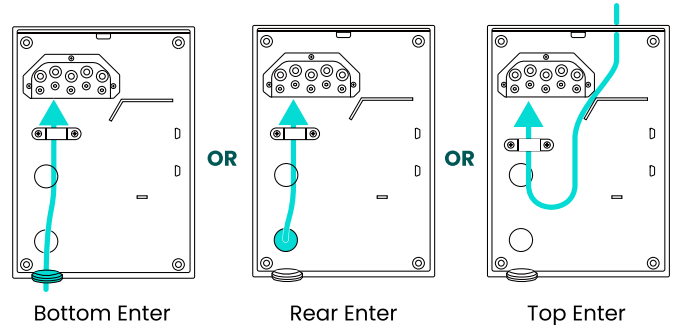

2. Connect the power wires to the terminal block according to the type of equipment (single-phase or three-phase) shown in the figure.

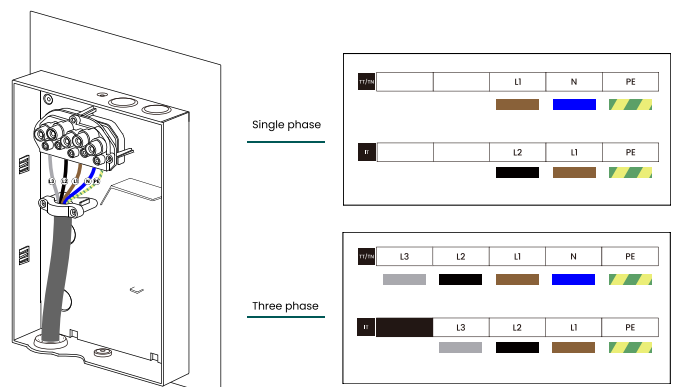

3. Installation and connection

3.5.4 Ethernet cable installation (For CT Kit/SC Kit/EMS)

1. There are two options available for input wiring: top and rear entry. Use an M25 hole saw to create the hole and install the rubber plug over the hole. (An M25 cable gland is recommended for the top entry.)



NOTE

Recommended reserved cable lengths:

- Top entry - 45cm
- Rear entry - 35cm

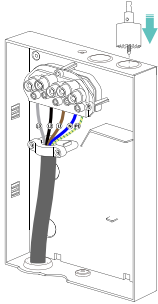

2. Run the Ethernet cable through the chosen hole and install the RJ45 connector.

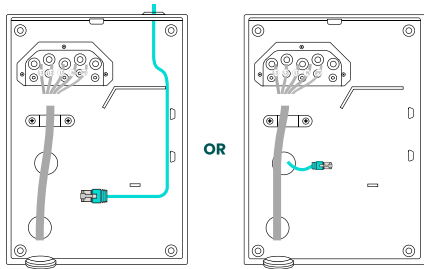

3. Plug in RJ45 port.

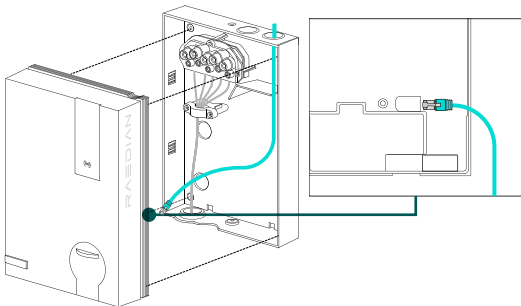

4. Securely clip the charger's body onto the backplate.

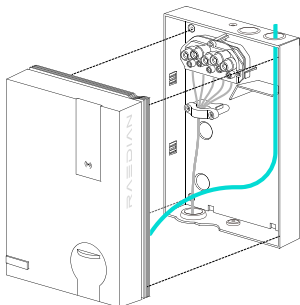

3.5.5 LAN connection (Apply to LAN version only)

1. Use an M25 hole saw to create the hole and install the dual cable gland.

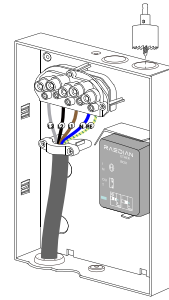

2. Remove the rubber stick from the cable gland. Run the Ethernet cable through the hole and install the RJ45 connector.

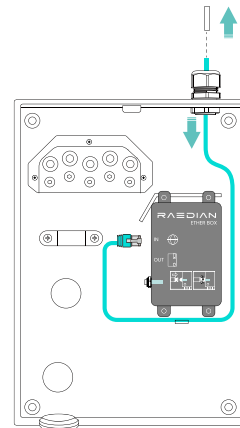

3. Connect the RJ45 connector of the Ethernet cable (connected to the router) to the LAN port (marked as IN) on the Etherbox.

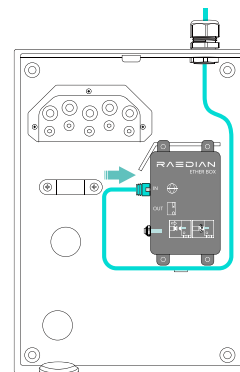

4. Tighten the dual cable gland.

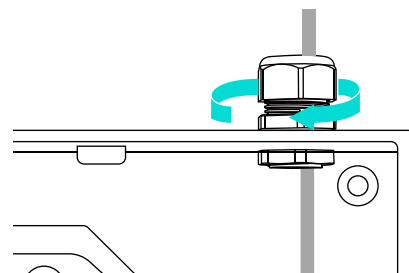

3. Installation and connection

3.5.6 CT Installation for home balance

Three phase power

1. For the 11kW and 22kW variants, connect CT2 and CT3 to the RJ45 connector according to the Ethernet cable type used (Straight-through or Cross-over). Follow the specific wiring sequence for the type of cable you are using.
2. Securely attach CT1 to L1, either upstream or downstream of the main circuit breaker. Ensure that the arrow on the CT clamp is pointing toward the load, and firmly clamp it until you hear a 'click'.
- Repeat the same steps for CT2 and CT3, attaching them to L2 and L3 respectively.
3. Connect the charger to the RJ45 adaptor using the Ethernet cable.

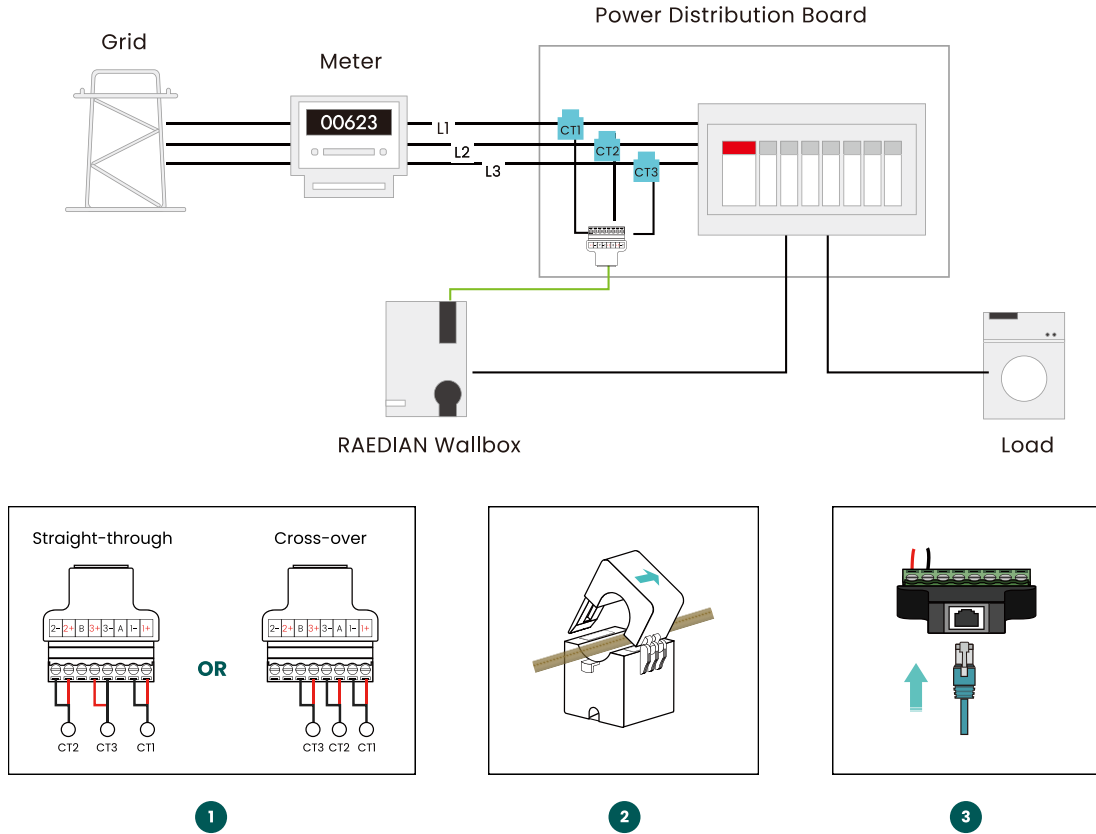

Single phase power

1. For the 7kW variants, connect CT to the RJ45 connector. Follow the wiring sequence as below.
2. Securely attach CT to L1. Ensure that the arrow on the CT clamp is pointing toward the load, and firmly clamp it.
3. Connect the charger to the RJ45 adaptor using the Ethernet cable.

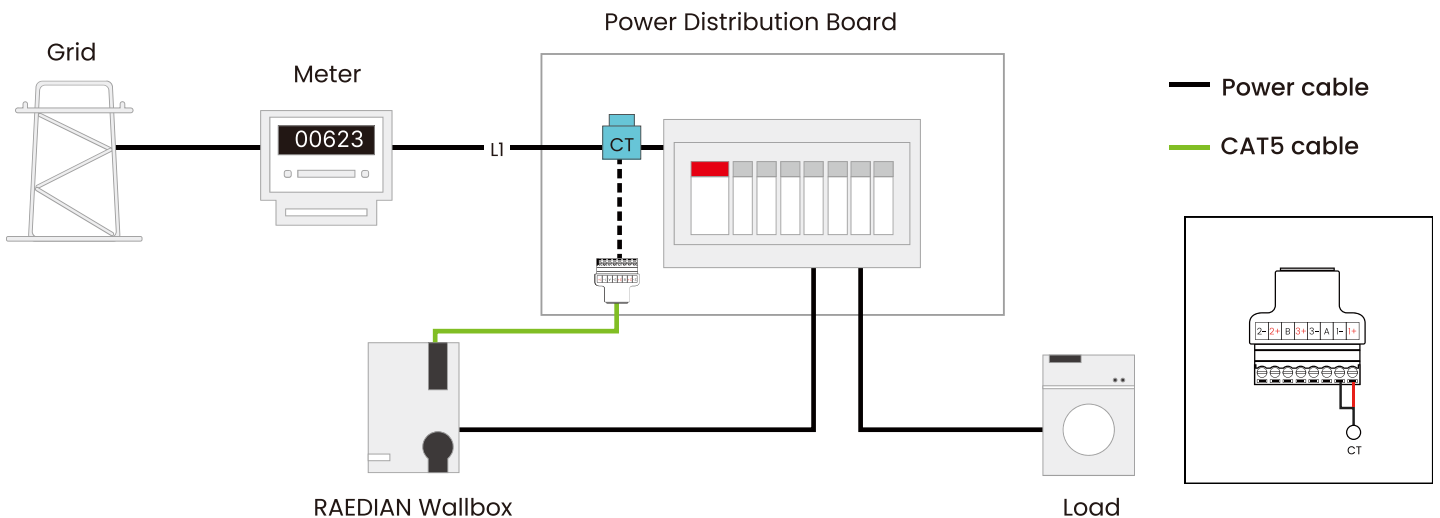

3. Installation and connection

3.5.7 CT Installation for solar charging

Single phase home with single phase pV

1. Connect CT1 and CT2 to the RJ45 connector. Follow the wiring sequence as below.
2. Securely attach CT1 and CT2 to LI. One is installed on the grid side and the other is on the PV side. Ensure that the arrow on the CT clamp is pointing toward the load, and firmly clamp it.
3. Connect the charger to the RJ45 adapter using the Ethernet cable.

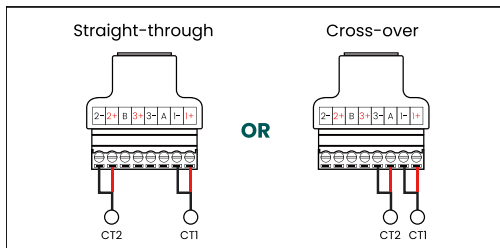
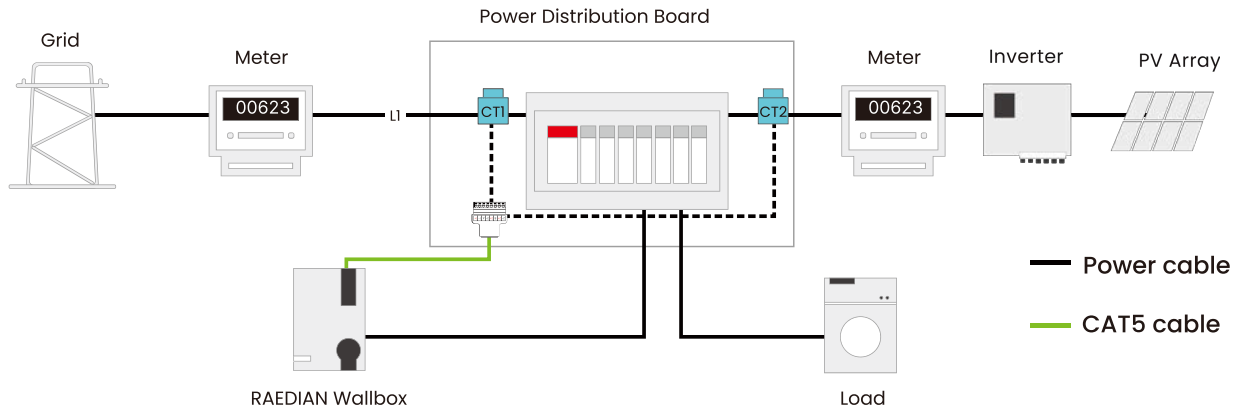

NOTE

If three-phase power, the SC Kit needs to be purchased to enable the solar charging function.

3.5.8 Additional installation procedure for load management with EMS

- NEO/NEO Plus supports load management through external EMS devices.
- Home Balance and Solar Charging will be not available when using EMS by setting ModbusRTU.
- Use the Ethernet cable to connect the charger and the external EMS device. Connect one RJ45 connector of the Ethernet cable to the charger in the same way as in 3.5.4.
- Another RJ45 connector of the Ethernet cable can be connected to the external EMS device through the provided CT adaptor.
 1. Remove the CT clamp connected to the CT adaptor
 2. Connect external EMS with RS-485 A and B on the CT adaptor.

3.5.9 Finishing the installation

The electrical installation is finished.

1. Tighten two security screws, one at the top and the other at the bottom of the charger.
2. Seal the top and bottom with two security stickers.



NOTE

Torque ≤ 6 N·m

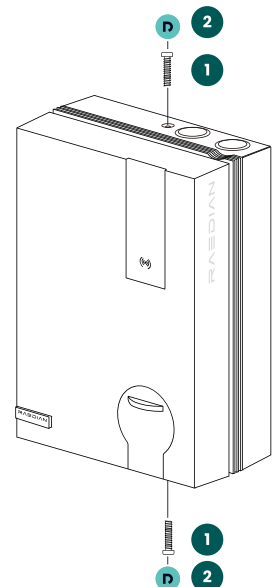

4. Acceptance test

4.1 Pre-Testing checks

Before testing your charging station, please follow these safety instructions:

- Ensure the charging station is properly connected to the power supply as described in this manual.
- Verify that the power supply distribution is individually protected by a suitable circuit breaker (or fuse).
- Confirm that the charging station is installed according to the instructions in this manual.
- Make sure the enclosure is securely closed.
- Measure the insulation resistance to ensure the charging cable is not tangled and that the cable, plug, and casing are free from damage.

4.2 Power on

- Turn on the local power supply.
- The charger will boot up and perform self-diagnostics within a few seconds.
- The charger's LED will display a white meteor effect and the charger is now ready for testing.

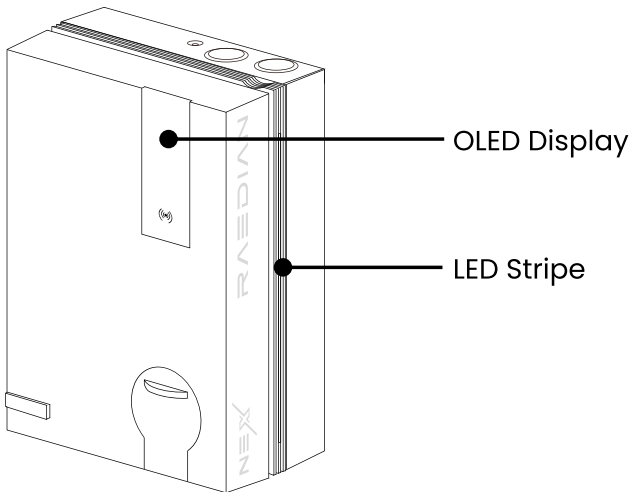

4.3 Perform charging test in plug and play mode

- Cable Variant: Insert the connector securely into the vehicle's AC charging port or the charging simulator, ensuring it is fully plugged in.
- Socket Variant: Insert the vehicle-end connector securely into the vehicle's AC charging port or the charging simulator, ensuring it is fully plugged in. Then, insert the charging cable's charger-end connector into the charger's socket securely, ensuring it is fully plugged in.
- The charging session will start automatically and the charger's LED will turn cyan with a falling drop effect.

5. HMI Description

5.1 Status indication

	LED Status	Definition
	White meteor	Standby, available for charging
	Green bouncing	Cable plugged in: <ul style="list-style-type: none"> • Pending for authorization • Waiting for EV • Charging stopped EV
	Cyan water drop	Charging in progress
	Red steady	Fault state
	Purple flashing	Pairing RFID cards

5.2 OLED display

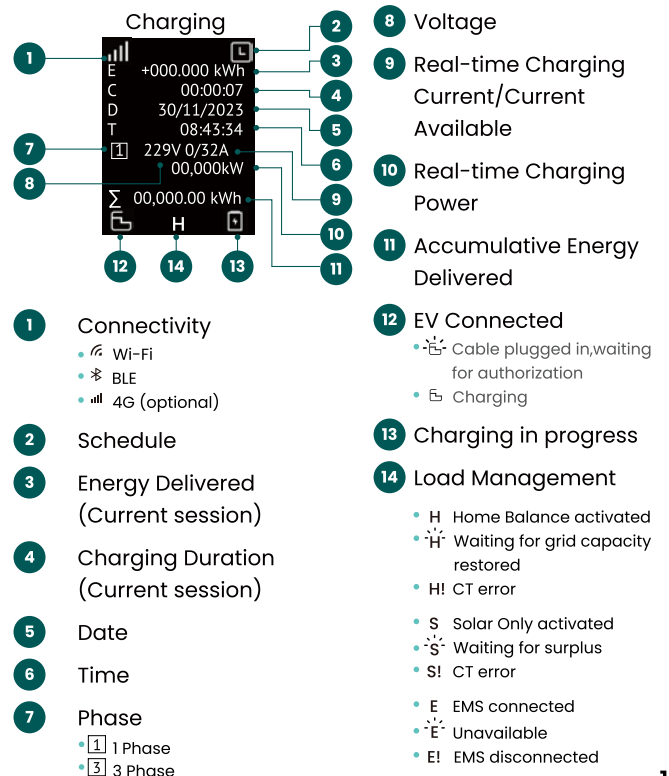
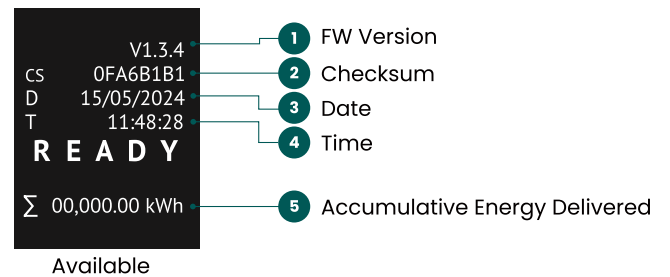
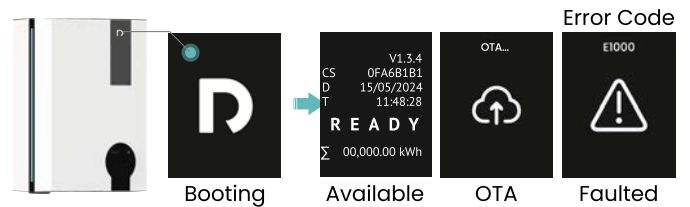

6. Configuration



NOTE

Before starting the configuration process, ensure the charger is properly installed and powered on.



NOTE

Keep Bluetooth enabled on your phone and ensure it remains close to the charger throughout the setup process.

6.1 Install RAEDIAN INSTALL APP

Download the RAEDIAN INSTALL APP from the App Store or Google Play, then install the app and register an account.



6.2 Connect with the charger

1. Choose NEO

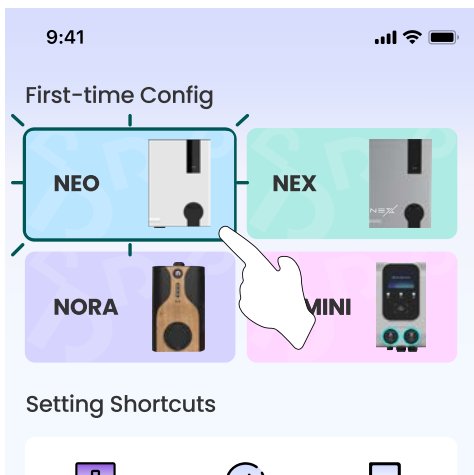

2. click "Connect wallbox"

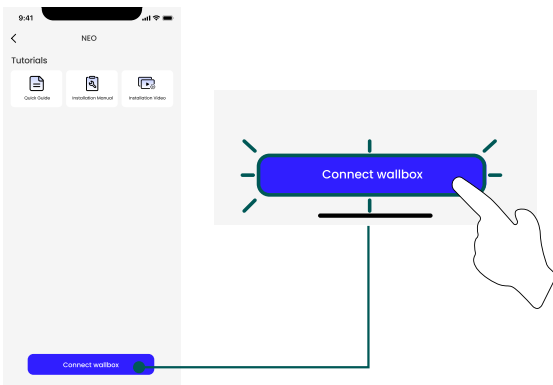

3. Find the correct Product Code on the searching list

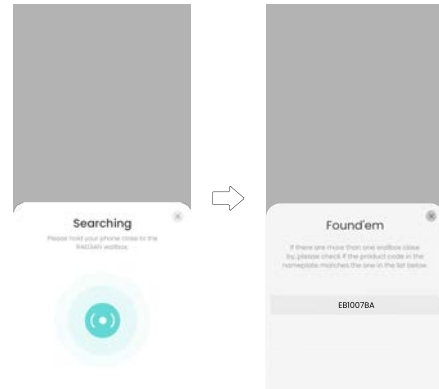

4. Enter the PIN Code and confirm. You can find it inside the charger and on the quick guide.

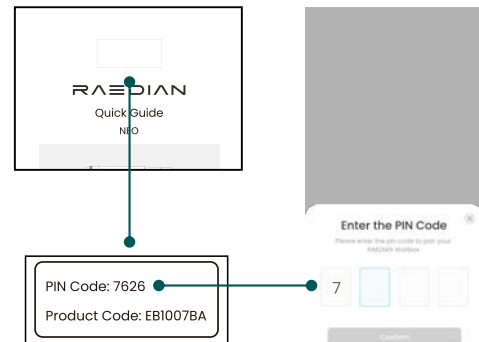

6.3 Configuration

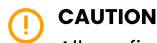

CAUTION

All configurations must be performed by a qualified electrician in accordance with the specific installation environment and local laws and regulations.



NOTE

To ensure all functions work properly, it is recommended to update the firmware to the latest version before configuration.



NOTE

It is required to install SC Kit before configuring dynamic load management.

Follow the steps in the app to complete the configuration.

For detailed instructions, visit www.raedian.com/support.

7. Technical specifications

7.1 General

Charging connector

NEO IEC 62196 Type 2 cable 5m, Type 2 socket, Type 2 socket with shutter

NEO Plus IEC 62196 Type 2 cable 7.5m, Type 2 socket, Type 2 socket with shutter

Authentication methods

Plug & Charge, RFID, RAEDIAN APP via BLE, OCPP Backend

HMI & indication

Dual LED stripes

Display

OLED display with status indicator and metering information

Nominal output voltage

Single phase: 230VAC \pm 20%, Three phase: 230/400VAC \pm 20%

Maximum output power

Single phase up to 7.4kW

Three phase up to 22kW with downgrade compatibility

Earthing system

TN/TT/IT

Protection

UVP, OVP, OCP, Relay Stuck, Over Temperature

Residual current protection

At least Type A RCD upstream +
Integrated 6mA DC per IEC 62955

Nominal frequency

50/60Hz

Metering accuracy

NEO Calibrated \pm 1% Accuracy

NEO Plus MID Certified Class B (\pm 1% Accuracy), Electrical Pulse output: 1000 imp/kWh, 0.25-5(32)A (11/22kW variants apply)

7.2 Connectivity

Vehicle communication

Mode 3 in accordance with, IEC 61851-1 ed. 3 (2017)

RFID authentication

ISO/IEC 14443A/B, 13.56 MHz, Maximum length: 7 bytes

Connectivity to backend

NEO Wi-Fi: 2.4GHz, 4G: LTE CAT I

NEO Plus Wi-Fi: 2.4GHz, Ethernet: RJ45, 4G: LTE CAT I

Connectivity to EMS/Meter

Modbus RTU via RS-485

Connectivity to smart phone

Bluetooth

SIM card

Two SIM options:

User SIM: Nano SIM, Settable APN user name and password
eSIM: Integrated, activated by Lifetime Connectivity Key

Backend protocol

OCPP 1.6(JSON) 2nd edition

7.3 Operating conditions

Operating temperature

-30 ~ 55°C with derating mechanism

IK protection (mechanical impact)

IK10

Relative humidity

5% ~ 95%

Operating altitude

3000m

Electrical safety class

Class I

Standby power

3.86W

Degree of protection (housing)

Charging core: IP55

Between charging core and backplate: IP54

Environmental conditions

Indoor / outdoor use

EMC Environmental conditions

Class B residential according to IEC 61851-21-2

7.4 Compliance

Safety

EN 61851-1, EN 62955, EN 62196, EN 61439

EMC

EN 61851-21-2:2021, EN 301489-1 V2.2.3:2019

EN 301489-3 V2.3.2:2023, EN 301489-17 V3.2.5:2022

EN 301489-52 V1.2.1:2021

RED

EN 300328 V2.2.2:2019, EN 300330 V2.1.1:2017,

EN 301908-1 V15.1.1:2021, EN 301908-13 V13.2.1:2022

MID

NEO Plus EN 50470-3, EN 62053-23

Health

EN 62311:2008, EN 50663:2017

EN 61000-6-2:2016, EN 61000-6-3:2006

RoHS

Directive 2011/65/EU & (EU)2015/863 Annex II

7.5 Mechanical

Mounting options

Wall mounted, Pedestal

Material

Polycarbonate, UV resistant and flame retardant, UL94 5VA

Casing (exterior) dimensions

297 x 210 x 110 mm (H x W x D)

Packaging dimensions (H x W x D)

450 x 360 x 230 mm (socket variant)

490 x 650 x 230 mm (cable variant)

Weight

NEO 4.3 - 7.2 kg

NEO Plus 4.7 - 8.5 kg



Zhejiang RAEDIAN New Energy Technology Co., Ltd
No.3, Shuangbai Road, Yuanhua Town
Haining City, Zhejiang, 314416
China